

Specification Approval Sheet

产品规格书

Customer Name 客户名称: _____

Customer Model 客户型号: _____

Customer P/N 客户编号: EiSTO-1182

Product Model 产品型号: EiSTO-803040

REC P/N 编号: _____

Prepared by 制作	Checked by 审核	Approved by 批准
李小兵	欧阳	吴俊

Customer Approved	Test by 测试	Checked by 审核	Approved by 批准
客户承认 (Stamp) (盖章)			

SHENZHEN EISTO ELECTRONICS CO.,LTD

Tel: +86-755-33273114 Fax: +86-755-33273118

E-mail: steven.koo@eistoelectronics.com

Add: Building 2,Zaimao Industry Park,Baoji Road,Bantian Street,Longgang District,
Shenzhen,China

Revision History

修改记录

Revision 修改	Description 描述	Date 日期	Approval 批准
1.00	New released	2016-12-27	吴俊

Contents 目录

1. Scope 概述-----	P04
2. Product basic information 产品基本信息-----	P04
3. Battery Outline Drawing 电池外形尺寸图 -----	P05
4. Electrical characteristics 充放电性能-----	P06
5. Condition adapting characteristics 环境适应性-----	P07
6. Cell safety performance 电芯安全性能-----	P08
7. Battery safety performance 电池安全性能-----	P10
8. Others 其他事项-----	P10
9. Testing requirements 测试要求-----	P11
10 Electrical Characteristics 电气特性-----	P11
11 Cell 电芯（参考）-----	P12
12. Electric Protect Features 电路保护参数-----	P13
13 Schematic circuit diagram 电路原理图-----	P14
14. PCB Parts List 保护板 BOM-----	P14
15. PCB Layout PCB 布线图-----	P14
16. Package 包装图-----	P15
17 Battery Precautions and Safety Instructions 电池组使用注意事项及安全说明-----	P16
Customer Inquiry 客户要求-----	P17

1. Scope 概述

The specification shall be applied to Lithium-ion Polymer (LIP) rechargeable battery pack which is manufactured by **SHENZHEN EISTO ELECTRONICS CO.,LTD.**

此产品规格书适用于深圳市亿盛弘电子有限公司制造的可充电锂离子电池。

Reference standard 参考标准:

GB/T 18287-2013、IEC/EN61960、UL1642

2. Product basic information 产品基本信息

Items 项目	Parameter 参数	
Battery model 电池型号	EISTO-803040	
Design scheme 设计方案	S-8261ABMMD-G3MT2x+8205A	
Nominal voltage 标称电压	3.7V	
Minimum capacity 最小容量	950mAh(0.2C discharge 放电)	
Typical capacity 典型容量	1000mAh(0.2C discharge 放电)	
Charging voltage 充电电压	4.2V	
Discharging cut-off voltage 放电截止电压	3.0V	
Standard charging 标准充电	0.2C /4.2V	
Max charging 最大充电	1.0C /4.2V	
Standard discharging 标准放电	0.2C/3.0V	
Max discharging 最大放电	1.0C/3.0V	
Weight 重量	Appr: 20.0g	
Shipment voltage 出货电压	≥3.85V	
Battery pack impedance 电池内阻	≤160mΩ	
Operating temperature 使用温度	Charging: 0°C ~ 45°C	
	Discharging: -20°C ~60°C	
Storage (At 50% SOC and specified temp, recoverable capacity in % vs time.) 存储 (50%容量下的存储时间和温度关系)	-10°C~25°C	(12 months, ≥85%)
	-10°C ~45°C	(6 months, ≥85%)
	-10°C~55°C	(1 month, ≥90%)
	20±5°C is the recommended storage temperature	
Visual Inspection 外观	There should not be any remarkable scratches, cracks, bolts, cauterization, deformations, swelling , leakage and so on on the surface of the cell. 禁止出现诸如撕裂、腐蚀、变形、气鼓、漏液等损害商业价值的不良现象。	

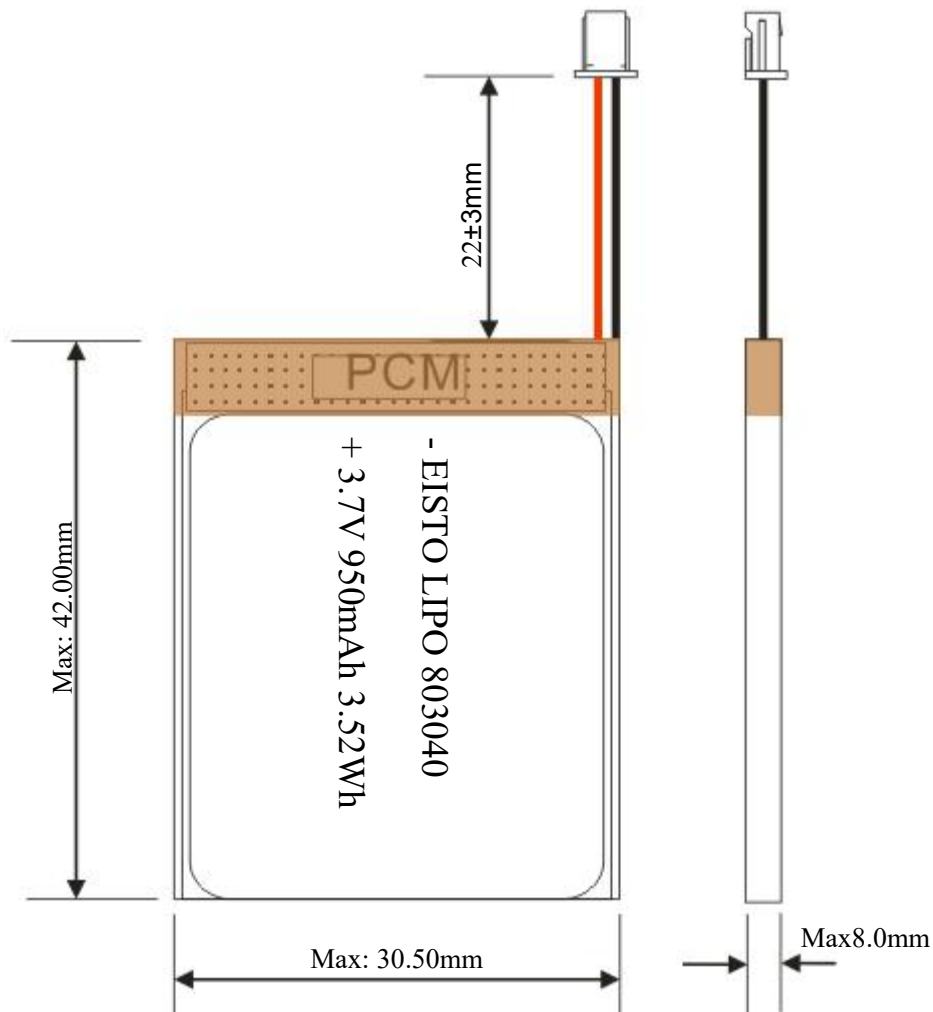
3. Battery Outline Drawing 电池外形尺寸图

BOM (Bill of materials) 电池物料清单

NO.	Material Name 零件名称	Specification 规格型号	Qty 用量	Remark 备注
1	cell 电芯	EISTO-803040/950mAh/3.7V	1	RoHS
2	Protection board 保护板	PCB2640-15	1	RoHS
3	Wire 引线	Red Wire 红线 客供	1	RoHS
		Black Wire 黑线 客供	1	RoHS
4	Connector 端子	客供 97-8000-602-008-829	1	RoHS

4. Electrical characteristics 充放电性能

No.	Items 项目	Test Method 测试方法	Criteria 标准
1	Standard Charge 标准充电	Charging the cell initially with constant current at 0.2C and then with constant voltage at 4.2V till charge current declines to 0.02C. 先以 0.2C 恒流充电，当电芯电压达到 4.2V 后，改为恒压充电直到充电电流小于或等于 0.02C。	N.A
2	Minimal Capacity 最小容量	The capacity means the discharge capacity of the cell, which is measured with discharge current of 0.2C with 3.0V cut-off voltage after the standard charge. 电芯满充电后，以 0.2C 电流连续放电至 3.0V 截止电压所放出的容量。	≥950mAh
3	Charge/Discharge Cycle 充放电循环	The capacity on 0.2C discharge shall be measured after 500 cycles Of 0.2C charge and discharge at 23±2°C. 23±2°C 条件下 0.2C 充放电循环 500 次。	Capacity≥80% 容量≥80%
4	Retention Capability 荷电保持能力	After full charging, storing the battery 28 days with 20 ± 5°C condition , and then staying 1 hours with discharge current of 0.2C till 3.0V cut-off voltage. 电芯满充电后，在 20±5°C 的环境条件下存放 28 天，搁置 1h 后以 0.2C 电流连续放电至 3.0V 终止电压。	Capacity≥85% 容量≥85%

※ Typical capacity 典型容量

The capacity means the average discharge capacity of the cell, which is measured with discharge current of 0.2C with 3.0V cut-off voltage after the standard charge at 23±2°C environment temperature, unit: mAh

典型容量指 23±2°C 温度下，以 0.2C 电流放电至终止电压 3.0V 时所放出容量对应的容量分布中心值，单位为 mAh。

5. Condition adapting characteristics 环境适应性

No.	Items 项目	Test Method 测试方法	Criteria 标
1	Constant temperature and Humidity 恒定湿热	After standard charging, put cell into the box that the temperature is $40\pm 2^{\circ}\text{C}$ and the humidity ranges between 90~95% for 48hours, then put it at $23\pm 2^{\circ}\text{C}$ for 2 hours, then discharge with current of 0.2C to the cut-off voltage. 满充电后将电芯放入 $40^{\circ}\text{C}\pm 2^{\circ}\text{C}$ 及相对湿度为 90~95% 的恒温恒湿箱中 48 小时后, 取出在 $23\pm 2^{\circ}\text{C}$ 环境下搁置 2h, 再以 0.2C 电流放电至 3.0V。	No distortion, no rust, no leakage, no venting, no rupture, no fire, no explosion, the discharge time is not less than 3hrs. 不变形、不锈蚀、不泄漏、不泄气、不破裂、不起火、不爆炸、放电时间不低于 3h。
2	High Temperature Performance Test 高温放电性能	After full charging, put the cell into box with high temperature of $55^{\circ}\text{C}\pm 2^{\circ}\text{C}$ for 2h, then discharge with current of 1.0C to the cut-off voltage. 电芯满充电后, 在 $55^{\circ}\text{C}\pm 2^{\circ}\text{C}$ 的高温箱中放置 2h, 然后以 1.0C 电流放电至终止电压。	No distortion, no rupture, no fire, no smoke or leakage Discharge time $\geq 51\text{min}$ 电池不变形、不破裂、不起火、不冒烟、不漏液。 放电时间 $\geq 51\text{min}$
3	Low Temperature Performance Test 低温放电性能	After full charging, put the cell into box with low temperature of $-10\pm 2^{\circ}\text{C}$ for 16~24h, then discharge with current of 0.2C to the cut-off voltage. 电芯满充电后, 在 $-10\pm 2^{\circ}\text{C}$ 的低温箱中放置 16~24h, 然后以 0.2C 电流放电至终止电压。	No distortion, no rupture, no fire, smoke or leakage Discharge time $\geq 3\text{h}$ 电池不变形、不破裂、不起火、不冒烟、不漏液。 放电时间 $\geq 3\text{h}$

6. Cell safety performance 电芯安全性能

No.	Items 项目	Test Method 测试方法	Criteria 标准
1	Cell Overcharge 电芯过充电	After discharge to limit voltage, charged at constant current of 3C and constant voltage of 4.6V, While voltage reaches to the max ,if charging continued over 7 hours or temperature is 20% less than the top , close the test . 电芯放电至终止电压后,用 3 C 电流和 4.6V 的极限电压充电,电压达到最大值后,当充电时间大于 7h 或者温度降至比峰值低 20%时终止测试。	No explosion and no fire. 无起火、爆炸
2	External Short-circuit Test 外部短路	Cell terminals are short-circuited to discharged state less than 0.1V or longer time with a resistance of 50mΩ or less. Tests are to be conducted at room temperature. 在室温环境中,将电池的端口用≤50mΩ电路相连接,直到电池放电电压≤0.1V。	No explosion and no fire. 无起火、爆炸
3	Over-Discharge Test 过放电	Cell is discharged at a current of 1C rate for 2.5 hours. (If current stops by safety or passive circuit on the battery, test is finished.). 用 1C 的电流放电 2.5 小时(如果电池由于安全保护启动致电池放电停止,则测试完成)。	No explosion and no fire. 无起火、爆炸
4	Crush Test 挤压	Crush between two flat plates. Applied force is about 13kN. 在电池的正反面上各放 1 个平面,用 13KN 的压力作用与此两平面对电池进行挤压。	No explosion and no fire. 无起火、爆炸
5	Impact Test 重物冲击	Impact between bar (15.8mm diameter) and 9.1Kg falling material (at a height of 6.1cm). Bar is laid across the center of the test sample. 将直径为 15.8mm 的金属棒横放在电池的大面中间,将 9.1Kg 的重物在金属棒的上方 6.1cm 的高处自由落下冲击金属棒。	No explosion and no fire. 无起火、爆炸

6	Drop 自由跌落	<p>After standard charging, the cell is to be dropped from a height of 1.2meter onto a thickness of 20mm board, dropped once in the positive and negative directions of three mutually perpendicular X, Y, Z axes.</p> <p>满充电电芯从 1.2 米高处自由跌落到 20mm 厚的硬木板上，从 X, Y, Z 正负方向每个方向自由跌落一次。</p>	<p>No leakage, no smoke, no fire , no explosion.</p> <p>无漏液、冒烟、起火、爆炸</p>
7	Vibration Test 震动	<p>Fixed the fully charged cell to vibration table and subjected to vibration cycling that the frequency is to be varied at the rate of 1Hz per minute between 10Hz and 55Hz, the excursion of the vibration is 0.8mm. The cell shall be vibrated for 90 ~100 minutes per axis of XYZ axes.</p> <p>电池按照振幅为0.8mm的谐振形式进行振动。振动频率在 10和55Hz间以1Hz / min的速率变化，往复振动90~100min。电池应该在互相垂直的三个面进行测试。</p>	<p>No explosion, no fire. no leakage.</p> <p>无起火、爆炸、漏液</p>
8	Heating 热冲击	<p>After standard charging, put cell in the baking oven and start , the temperature of the oven is to be raised at a rate of $5\pm 2^{\circ}\text{C}$ per minute to a temperature of $130\pm 2^{\circ}\text{C}$, remain for 30minutes at that temperature.</p> <p>将电芯满充电后，放置于热箱中，温度以 $(5\pm 2^{\circ}\text{C}) / \text{min}$ 的速率升至 $130^{\circ}\text{C}\pm 2^{\circ}\text{C}$ 并保温 30min。</p>	<p>No explosion and no fire.</p> <p>无起火、爆炸</p>

7. Battery safety performance 电池安全性能

1	Overcharge protection 过充保护	<p>After battery charge finished, then charge the battery for 8 hours with a power which can provide 2 times more than nominal voltage and $2C_5A$ current.</p> <p>电池充电结束后，用 $2C_5A$ 电流和 2 倍标称电压输出的电源继续充电 8 小时。</p>	<p>No fire, no explosion. The electrical properties of normal.</p> <p>无起火、爆炸。电性能正常</p>
2	Over discharge protection 过放保护	<p>After the battery is fully charged, discharge at $20\pm 5^\circ C$ conditions with $0.2C_5A$ until the battery voltage drops to the over discharge voltage, then discharge with a 30Ω resistor for 24 hours.</p> <p>电池满充电后，在 $20\pm 5^\circ C$ 条件下，以 $0.2C$ 放电至终止电压后，外接 30Ω 负载放电 24h。</p>	<p>No fire, no explosion. The electrical properties of normal.</p> <p>无起火、爆炸、电性能正常</p>
3	Short protection 短路保护	<p>After standard charging, connect the positive and negative terminals of the cell with copper wire having a maximum resistance load of $0.1\ \Omega$ at room temperature, the test is discontinued when the surface temperature lower than $10^\circ C$.</p> <p>满充电后，将接有热电偶的电芯置于通风橱中，短路正负极（线路总电阻不大于 0.1Ω），试验过程中，监视电芯温度变化，当温度下降到比峰值低约 $10^\circ C$ 时，结束试验。</p>	<p>The battery shall no rupture, smoke, catch fire, or leakage.</p> <p>Battery Voltage $\geq 3.6V$</p> <p>电池外观应无明显损伤、冒烟、起火或漏液。</p> <p>电池电压 $\geq 3.6V$。</p>

8. Others 其他事项

Any matters that this specification doesn't cover should be conferred between the customer and EISTO.

任何本规格书中未提及的事项，需要经双方协商确定。

9. Testing requirements 测试要求

9.1 Battery test environment 电池试验环境

Temperature 温度: $23\pm 2^{\circ}\text{C}$

Relative humidity 相对湿度: $60\pm 20\%$ RH

Atmospheric pressure 大气压力: $86\sim 106$ KPa

9.2 Measuring instrumentation requirements 测量仪表要求

Voltage instrumentation requirements: Measuring the voltage meter accuracy no less than 0.5 magnitude

电压仪表要求: 测量电压的仪表的精确度不低于 0.5 级

Current instrumentation requirements: Measuring the current meter accuracy no less than 0.5 magnitude

电流仪表要求: 测量电流的仪表精确度不低于 0.5 级

Time instrumentation requirements: Measuring the time meter accuracy no less than 0.1%

时间仪表要求: 测量时间的仪表精确度不低于 0.1%

Temperature instrumentation requirements: Measuring the temperature meter accuracy no less than 0.5°C

温度仪表要求: 测量温度的仪表准确度不低于 0.5°C

Impedance instrumentation requirements: Measuring impedance should by sinusoidal alternating (1 KHZ) test

内阻仪表要求: 测量内阻应由正弦交变(1KHZ)进行测试

10. Electrical Characteristics 电气特性

10.1 Battery charge/discharge 电池组充/放电

10.1.1 Full charged definition 充电定义

With charging voltage 4.2V, current 0.2C continued to charge the battery pack, when charging current drops to 0.02C charging is terminated, shall be full charged.

以充电电压4.2V, 电流0.2 C 对电池组持续充电, 当充电电流下降至0.02C 时充电被终止, 即为充电。

10.1.2 Full discharged definition 放空定义

Standard discharge current 0.2 C for continuous discharge, when the voltage drops to discharge cut-off voltage 3.0V discharge is terminated, shall be full discharged.

以标准放电电流 0.2 C 进行持续放电, 当电压降至放电截止电压 3.0V 时放电被终止, 即为放空。

11. Cell 电芯 (参考)

11.1 Performance parameters 性能参数

编号	项 目	规 格	备 注	
1	Cell minimum capacity 电芯最小容量	950mAh	0.2C discharge 放电	
2	Initial impedance 初始内阻	$\leq 60\text{m}\Omega$	1kHz AC Impedance 交流阻抗 AC 1kHz	
3	Nominal voltage 标称电压	3.7V	/	
4	Dimensions 外形尺寸	T	8.0mm Max	Thickness 厚度
		W	30.5mm Max	Width 宽度
		L	40.5mm Max	Cell length (not include Tab sealant) 电芯长度 (不含极耳胶)
		A	$14.0 \pm 2.0\text{mm}$	Distance of tab center 极耳中心距
		B	$3.0 \pm 0.2\text{mm}$	Tab width 极耳宽度

11.2 Cell outline drawing 电芯外形尺寸

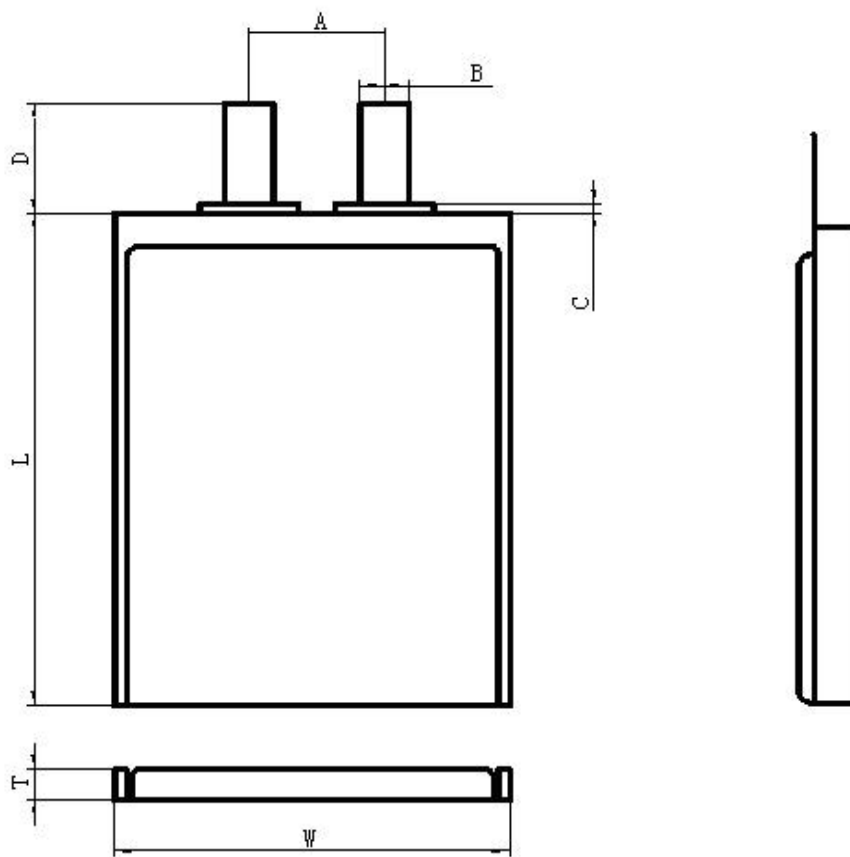

12. Electric Protect Features 电路保护参数

Item 项目	Syol 符号	Content 内容	Criterion 标准
Over charge Protection 过充保护	V_{DET1}	Over charge detection voltage 过充保护电压	4.28±0.05V
	tV_{DET1}	Over charge detection delay time 过充保护延迟时间	0.96~1.4s
	V_{REL1}	Over charge release voltage 过充恢复电压	4.08±0.05V
Over discharge protection 过放保护	V_{DET2}	Over discharge detection voltage 过放保护电压	2.8±0.10V
	tV_{DET2}	Over discharge detection delay time 过放保护延迟时间	115~173ms
	V_{REL2}	Over discharge release voltage 过放恢复电压	2.8±0.10V
Over current protection 过流保护	V_{DET3}	Over current detection voltage 过流保护电压	100±30mv
	I_{DP}	Over current detection current 过流保护电流	1.5~3.5A
	tV_{DET3}	Detection delay time 延迟时间	7.2~11.0ms
		Release condition 恢复条件	Cut load
Short protection 短路保护		Detection condition 检测条件	Exterior short circuit
	T_{SHORT}	Detection delay time 短路延时	220~380μs
		Release condition 恢复条件	Cut short circuit
Interior resistance 内阻	R_{DS}	Main loop electrify resistance 回路内阻	$V_C=4.2V$; $R_{DS} \leq 70m\Omega$
Current consumption 工作消耗	I_{DD}	Current consume in normal operation 工作消耗电流	3.0μA Type 7.0μA Max 0V Charging
0V Prohibition /allowance 0V 充电禁止/容许		allowance	

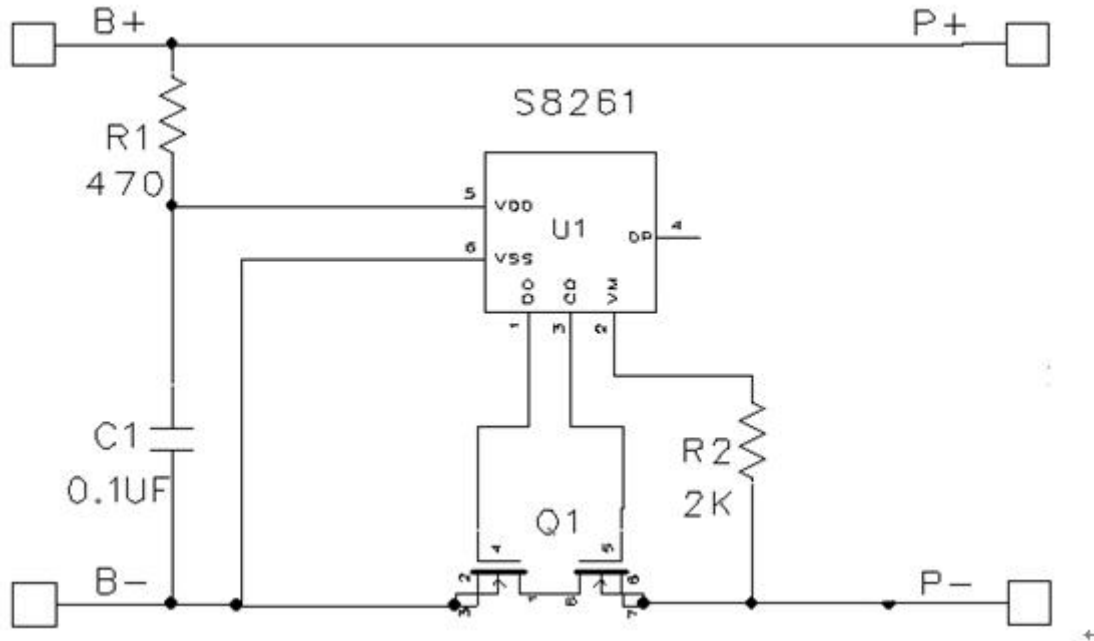
13. Schematic circuit diagram 电路原理图

14. PCB Parts List 保护板 BOM

Item 序号	Part Name 元件	Description 规格	QTY 数量	Footprint 封装	Supplier 供应商	Remark 备注
1	U1	S-8261ABMMD-G3MT2x	1pcs	SOT-23-6	SEIKO	
2	Q1	8205A	1pcs	STOOP-8	MT	
3	C1	0.1μF	1pcs	0603	Any approved vendor	
4	R1	470Ω±5%	1pcs	0603	Any approved vendor SKYWELL, YAGEO, or any	
5	R2	2.0KΩ±5%	1pcs	0603	Any approved vendor SKYWELL, YAGEO, or any	
6	PCB	PC2640-15	1pcs		Any approved vendor	

15. PCB Layout PCB 布线图

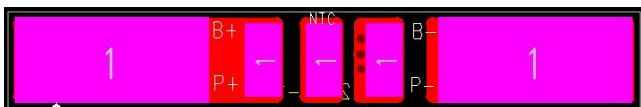
Top Layer



Bottom Layer

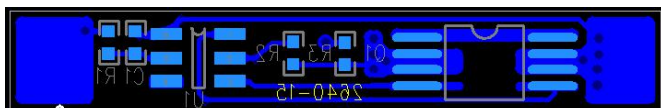

16. Package 包装图

REV.	MARK	DESCRIPTION	SIGNATURE	DATE
A		FIRST DESIGN RELEASE		
	△			
	△			
	△			
	△			

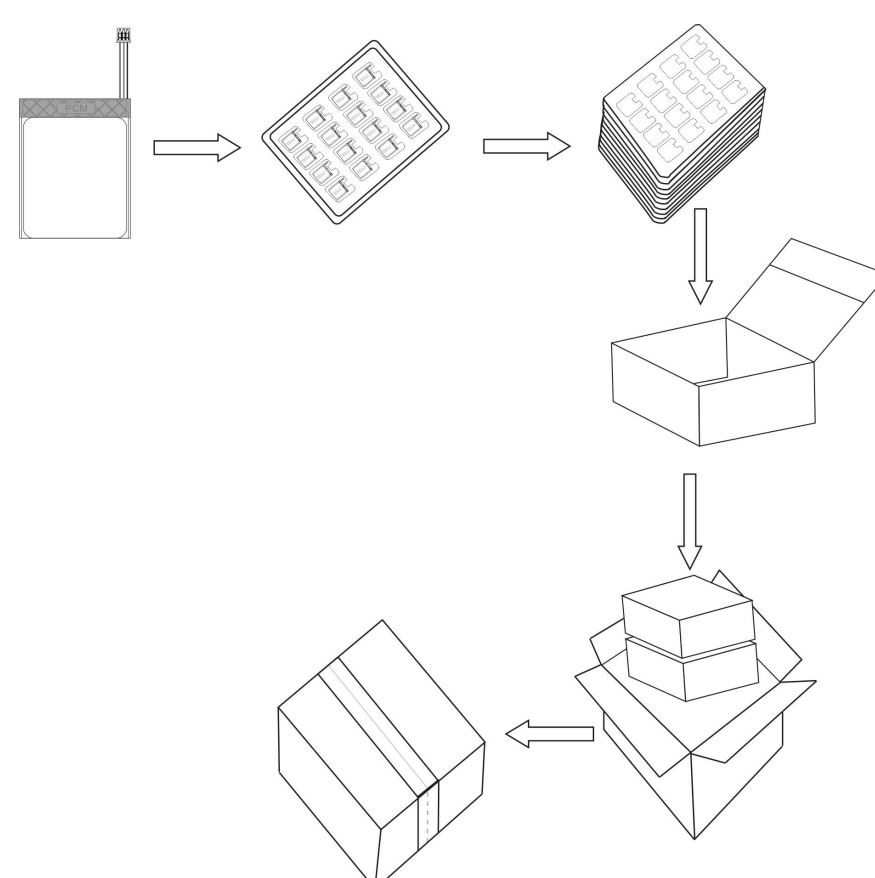

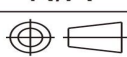
产品名 MODEL				部件名 TITLE	包装示意图		图号 DWG NO	N/A	
材料 MATERIAL	如明细表		设计 DRAWN	审核 CHECKED	审定 APPROVED	日期 DATE			
表面处理 FINISH	N/A		比例 SCALE	N/A	数量 QTY	物料编码 STOCK NO.		N/A	版次 REV
未注公差 GENERAL TOLERANCE	±0.1mm		DO NOT SCALE DRAWING ALL DIMENSION ARE IN mm			尺寸单位 毫米			图幅 SIZE
部件编号 P/No	N/A								A4

17. Battery Precautions and Safety Instructions 电池组使用注意事项及安全说明

Please be sure to take to comply with the specifications and the following precautions to use with batteries, did not follow the specifications for the operation caused any accidents, SHENZHEN EISTO ELECTRONICS CO.,LTD. will not accept any responsibility.

请您务必遵守本规格书和以下使用注意事项使用电池, 对于没有按照规格书进行操作所造成的任何意外事故, 亿盛弘电子有限公司将不承担任何责任.

- Guarantee to keep the battery in good repair in 12 months from the shipment.

从出厂代码日起 12 个月内保修.

- Please use 0.5C current to charge up 60% capacity after the battery placed 3 months.

电池每放置三个月,请预先以 0.5C 充电 1 次,即让电池具备 60%以上的电量.

- Before Use the battery, carefully read the instruction manual and battery labels on the surface.

使用电池前, 请仔细阅读使用说明书和电池表面标识.

- Need to use the original battery charger, and should be placed in a dry ventilated place.

电池需使用原装充电器充电, 并应放置在干燥通风场所.

- Such as long-term when not in use, the battery charger to charge state half full, remove the battery from the device and separated, to avoid metal contact with the battery, causing short-circuit or damage to the phenomenon.

如长期不使用时, 请将电池充电至半满电荷状态, 把电池从设备中拆除并分开放置, 避免金属接触电池, 造成短路或损坏现象.

- In use or during storage, battery found there has been high fever, leakage, odor, distortion and other anomalies, please stop using it immediately and stay away from the battery.

在使用或储存期间, 如发现电池有出现高温发热、漏液、散发异味、变形及其它异常现象时, 请立即停止使用并远离电池.

- Do not short-circuit the battery positive and negative, and careful not to allow the battery to moisture, to avoid danger.

切勿将电池正负极短路, 并注意不可让电池受潮, 以免发生危险.

- Using, keep away from heat, High pressure place, and do not beat, hit the battery.

使用过程中, 应远离热源、高压场所, 并勿摔打、撞击电池.

- Battery end of life should be immediately removed from the equipment, Please properly handle security of spent batteries, do not put into fire or water.

电池寿命终止应立刻从设备中取出,废弃电池请安全妥善处理, 切勿投入火中或水中.

Customer Inquiry

客户要求

1. IF clientele ratify specification and showpiece, please sign back specification to EISTO in 1 week,
如果客户认可规格书和样品，请下订单前及时回签规格书给亿盛弘电子
- 2、The customer is requested to write down your information and contact EISTO in advance, if and
when the customer needs applications or operating conditions other than those described in this
document.EISTO could design and build such products according to your special request.

如果客户需要其他方面的说明或工作条件与规格书内容不一致,请客户提前和亿盛弘电子有限公司联系. 亿盛弘电子有限公司将按照贵公司特殊要求设计和开发产品.特殊要求标准:

	Special Request 特殊要求	Criteria 标准
1		
2		
3		
4		
5		
6		

Company Name : _____ Signature : _____ Date: _____

公司名称

签名

日期